

Race Technology

DL1 CLUB

Instruction manual



Table of Contents

1	DL1 CLUB INTRODUCTION	4
1.1	WHAT IS THE DL1 CLUB?.....	4
1.2	WHO IS THE DL1 CLUB DESIGNED FOR?	4
1.3	WHAT DOES THE DL1 CLUB DO?	4
1.4	WHY USE GPS?	5
1.4.1	<i>Track Mapping</i>	5
1.4.2	<i>Speed Measurement</i>	5
1.5	DL1 CLUB FEATURES.....	5
2	TECHNICAL SPECIFICATION.....	7
2.1	IDENTIFYING YOUR UNIT	8
3	INSTALLING THE UNIT	9
3.1	MOUNTING	9
3.1.1	<i>Bracket Mounting</i>	10
3.2	POWER.....	10
3.3	FURTHER READING	11
4	QUICK START GUIDE.....	12
4.1	INSTALLING THE DL1 CLUB IN THE VEHICLE	12
4.1.1	<i>Mounting the DL1 CLUB in the vehicle</i>	12
4.1.2	<i>Correct Mounting of the GPS Antenna</i>	12
4.1.3	<i>Recommended mounting positions for the GPS antenna</i>	13
4.1.4	<i>Connecting the GPS module (if used)</i>	14
4.1.5	<i>Connecting the power cable</i>	14
4.2	DEFAULT CONFIGURATION.....	14
4.3	LOGGING DATA USING THE DL1 CLUB.....	15
4.3.1	<i>Powering up the DL1 CLUB</i>	15
4.3.2	<i>Insert an SD card</i>	15
4.3.3	<i>Sampling data</i>	15
4.4	ANALYSING DATA FROM THE DL1 CLUB	15
4.4.1	<i>Installing the SD card reader</i>	15
4.4.2	<i>Installing the software on the PC</i>	16
4.4.3	<i>Loading the data into the software</i>	16
4.4.4	<i>Display the track map and a graph of speed for the entire run</i>	16
4.4.5	<i>Display your acceleration and braking times.</i>	16
4.4.6	<i>Displaying lap and sector times</i>	16
4.4.7	<i>Automatically generating a graph comparing speeds on two laps</i>	16
5	OPERATING THE DL1 CLUB	17
5.1	DESCRIPTION OF THE PLUG/CONNECTIONS/LIGHTS ETC ON THE DL1 CLUB	17
5.2	SAMPLING DATA WITH THE DL1 CLUB	20
5.2.1	<i>To stop data logging</i>	20
5.2.2	<i>Advanced operation</i>	20
5.3	REAL TIME OUTPUT	20
5.4	FURTHER READING.....	20
6	CONNECTING EXTERNAL SENSORS TO THE DL1 CLUB	21
6.1	CONNECTING GPS	21
6.2	EXTERNAL SENSORS.....	21
6.3	CONNECTING A WHEEL SPEED SENSOR	22
6.4	REMOTE START/LOGGING INDICATOR.....	22

7	DL1 CLUB CONNECTOR DETAILS	23
7.1	REAR VIEW	23
8	HOW DO I?	27
8.1	HOW DO I MANUALLY START AND STOP LOGGING ON MY DL1 CLUB?	27
8.2	HOW DO I KNOW WHAT KIND OF DL1 I HAVE?	27
8.2.1	<i>The early DL1 Mk1</i>	27
8.2.2	<i>The later DL1 Mk1</i>	28
8.2.3	<i>The DL1 Mk2</i>	28
8.2.4	<i>The DL1 MK3/CLUB</i>	28
8.3	LOAD A LICENCE FILE	29
8.4	HOW DO I CONNECT A START/STOP SWITCH WITH INDICATOR?	29
8.5	CONNECT AND SET UP A GOPRO INTERFACE CABLE	30
8.6	HOW DO I CONNECT A LOGGING INDICATOR?	31
8.7	HOW DO I FIT A CABLE TO THE BLACK CONNECTOR THAT IS USED TO POWER THE DL1 CLUB?	32
8.8	HOW DO I CONNECT A 1 OR 2 WIRE SENSOR TO THE DL1 CLUB	33
8.8.1	<i>Choosing a value for the pull up resistor</i>	34
8.9	HOW DO I READ DATA FROM MY ECU AND DISPLAY IT ON MY DASH1/DASH2 OR LOG IT ON MY DL1 CLUB?	35
8.10	LOG DASH2 ANALOG INPUTS	35
8.11	WHY WON'T MY DL1 CLUB WORK?	37
8.12	CONNECT AN RPM INPUT.....	37
8.13	HOW DO I FIND OUT WHY MY LOGGER STOPPED LOGGING DURING A RACE?	39
9	FREQUENTLY ASKED QUESTIONS.....	40
9.1	WHAT IS THE DIFFERENCE BETWEEN THE DL1 MK3/CLUB AND THE DL1 MK1/2?	40
9.2	WHAT IS THE MAXIMUM G-FORCE/SPEED THAT CAN BE MEASURED?	41
9.3	HOW OFTEN DO YOU GET GPS SPEED UPDATES?	41
9.4	HOW OFTEN DO YOU GET GPS POSITION UPDATES?.....	41
9.5	HOW ACCURATELY IS SPEED MEASURED?	41
9.6	HOW ACCURATELY IS POSITION MEASURED?.....	41
9.7	WHAT HAPPENS TO THE DATA IF YOU DRIVE UNDER A BRIDGE/TUNNEL/TREES ETC?.....	41
9.8	WHERE CAN I BUY IT?	41
9.9	IS IT UPGRADEABLE?	42
9.10	HOW MUCH DATA CAN YOU LOG TO AN SD CARD?	42
9.11	WILL IT WORK WITH ANY SD CARD?.....	42
9.12	IS IT EASY TO USE?	42
9.13	WHAT SPECIFICATION OF COMPUTER IS REQUIRED?	42
9.14	IS THE DL1 CLUB RELIABLE AND WELL MADE?.....	42
9.15	WHAT OPTIONS DOES MY DL1 CLUB HAVE INSTALLED?	43
9.16	CAN I ADD EXTRA OPTIONS TO MY DL1 CLUB?.....	43
10	DL1 CLUB SOFTWARE	44
10.1	THE ANALYSIS SOFTWARE	44
10.2	THE REALTIME MONITOR	44
10.3	THE LITE MONITOR	44
10.4	THE CONFIGURATION TOOL	44
10.5	RE-FLASHING YOUR UNIT	44

1 DL1 CLUB Introduction

The DL1 CLUB was previously known as the DL1 MK3, the two products are identical, so any reference to DL1 MK3 equally applies to DL1 CLUB and vice versa.



1.1 What is the DL1 CLUB?

The DL1 CLUB is a completely updated version of the DL1. It is a state-of-the-art vehicle data logging and control system. Put in the simplest terms, it stores a wide range of vehicle data for later analysis on a computer - the system does not include an in-vehicle display, Race Technology has a number of dashboard solutions available for the DL1 CLUB.

1.2 Who is the DL1 CLUB designed for?

The DL1 CLUB is designed for autosport applications including drag racers, single seater racing cars, rally cars or road cars - however it is also ideal for use on power boats, go karts and motorbikes. It is also an ideal platform for use in the auto industry for car testing of all types, from long term monitoring to competitor benchmarking.

1.3 What does the DL1 CLUB do?

The DL1 CLUB can store data from a number of sources including its built in high accuracy GPS and accelerometers, wheel speeds, shaft speeds, engine speeds, temperatures, pressures, lap times, sector times etc. The DL1 CLUB comes packaged with the excellent Race Technology data analysis package for Windows. The software allows super accurate track mapping, user defined channels, powerful graphing and allows direct comparison of up to 10 data sets (races) simultaneously with almost unlimited laps. The DL1 CLUB can also be used to supply data to dashboard displays and to drive auxiliary outputs to control fans, pumps, or lights.

1.4 Why use GPS?

One of the key features of the DL1 CLUB is its built in high accuracy GPS system - this gives the DL1 CLUB advantages over other data loggers in 2 key areas - greatly improved track maps and far more accurate speed data.

1.4.1 Track Mapping

Conventional data loggers require a "closed circuit" to enable them to calculate the track map; the shape of the track is estimated from a combination of the lateral acceleration and speed. This works adequately in some situations but it becomes increasingly inaccurate for long tracks and impossible for open circuits, motorbikes or boats. In contrast, the GPS will produce high accuracy track maps in almost any situation.

1.4.2 Speed Measurement

While speed is probably the most important parameter that anyone wants to measure using the data logging system, it is also the most inaccurate in a "conventional" system. The normal way to measure speed is to simply attach a pickup to a wheel to detect how fast it is rotating - but the rolling circumference of a tyre changes by 4% just with wear and temperature. Even worse, the error increases significantly under race conditions where the tyre is under load - typically the tyre slips by up to 20% under hard braking going into a corner. Measuring speed using GPS is now common practice in high-end systems - under typical conditions speed error is well under 1%!

1.5 DL1 CLUB Features

The DL1 CLUB is an all-new, 3rd generation, data logger system from Race Technology. It is a complete redesign of the DL1, retaining all the best features and improving and adding where possible. Some of the most noteworthy features include:

- **Built in GPS**

The new GPS unit is based on our own high accuracy GPS3 technology and calculates position and speed 5 times every second. This is easily the fastest, most accurate GPS system available for under \$1500. The measurements from the GPS and accelerometers are combined to calculate very high accuracy positions and speeds at 100 times a second. Optional storage of raw GPS data for post processing at 20Hz is also possible.

- **Built in accelerometers**

Built in 3-axis accelerometer with 2g full scale (optional 6g full scale).

- **Built in yaw gyro for slip angle measurement (optional)**

- **Logging to SD cards**

Works with SD and SDHC, for up to 32GB storage.

- **Up to 12 analogue inputs**

The DL1 CLUB has 12 very high accuracy analogue inputs. All inputs have a maximum of 25V input

- **Up to 4 output drivers**

Low side driver outputs are available for controlling pumps, fans, lights.

- **2 RPM inputs**

The DL1 CLUB has 2 RPM inputs, only one of which can be used at any one time. One input is designed to be connected to "high level" sources, such as the ignition coil. The other input is designed for low level signals such as a feed from the ECU.

- **4 wheel/shaft speed inputs**

The DL1 CLUB features 4 totally independent wheel/shaft speed inputs. These can be used to measure the speed of all four wheels, or slip ratios across a torque converter for example.

- **Two RS232 ports**

Either port can be used to receive data for logging, one port is always used for outputting data for storage to a VIDEO4 or to a DASH display.

- **CAN port**

CAN port enable receiving and transmitting of messages at configurable rates up to 1Mbit/s

- **Remote start/stop and add marker inputs**

- **Dual 5v reference outputs**

Two independent 5v outputs can be used to drive up to 500mA each for sensor outputs.

- **Simple operation**

A single button to start or stop logging, it's as simple as that! If the button is inaccessible from the driver's seat then a remote button and status indicator can be added if required.

- **Power supply requirements**

The power supply to the DL1 CLUB data logger can be taken directly from the vehicles 12v supply, or it can be powered from its own battery if required. The power supply is smoothed and regulated within the DL1 CLUB ensuring its performance is highly robust and stable.

- **USB interface**

USB connection for direct connection to a PC for configuration

- **Testing**

Very high reliability is ensured by calibrating, temperature testing and vibration testing each unit on an individual basis. Autosport applications make tremendous

demands on electronic systems and we take great care to make sure our products are up to the task. All the connections to the units are vibration proof, high strength to ensure that connections do not fail at the critical time.

- **Powerful**

The DL1 CLUB has the latest 150MHz processor for maximum expandability and functionality

2 Technical Specification

Memory	SD memory card, can be SD or SDHC. Up to 32GB. FAT32 only
GPS	Outputs position, speed, position accuracy and speed accuracy at 5Hz with no interpolation. GPS tracking loops optimised for applications up to about 4g. tracking of all satellites in view. 20Hz raw data storage for post-processed operation
GPS Antenna	Magnetic base, 3.3v active antenna with SMA connector.
Analogue Inputs	12 external inputs, all 12 bit resolution and 0-25v. All inputs are protected and filtered. Accuracy = 0.4% of measured voltage.
Frequency Inputs	4 external frequency inputs with a maximum input frequency >2kHz. Triggering voltage requires a low input of <1v and a high input of >4v and 15v maximum.
Lap Marker Input	Triggering voltage requires a low input of <1v and a high input of >4v and 25v maximum.
Start Sample Input	Triggering voltage requires a low input of <1v and a high input of >4v and 25v maximum
Low level outputs	4 low side drivers, each capable of driving 500mA.
Power Supply Requirements	12v nominal input, minimum of 10v, maximum of 23v (higher voltages can be accommodated if specified at the time of ordering). Current consumption of about 180mA including GPS, dependant on SD card requirements. +5v Reference Out Maximum current draw 500mA x 2.
Ignition In Signal (High Level)	Designed to connect directly to negative terminal of ignition coil. Can also fire from fuel injectors and from CD ignition systems.
Ignition In Signal (Low Level)	Triggering voltage requires a low input of <1v and a high input of >4v and 15v maximum. Suitable for connection directly to most ECU tacho outputs. Maximum input frequency >300Hz.
Case Construction	Injection moulded ABS with polycarbonate front and back panels.

Connector Type	3.5mm pitch lever terminals
Main Processor	150MHz TI Digital Signal Processor
Serial Port 1	User configurable for messages. Transmission and reception of RT format messages at 115200 baud
Serial Port 2	Used for reception of RT messages at a fixed baud rate of 115200
CAN Port	Message reception and transmission up to 1MBit/s
Computer communication	USB port for reflashing and reading/writing configuration
Accelerometers	3 axis, precision digital output. Guaranteed 2g minimum full scale on both axes. Resolution of 0.005g. Optional 6g sensor available as a factory option.
Gyroscope	Single axis yaw rate gyro with a maximum rate of 300 degrees / sec.
Vibration	Factory tested at 25g, 50Hz sinusoid for 5 minutes (without compact flash card inserted).
Temperature	Factory tested from -20oC to 70oC

"WARNING": To avoid any possible damage to the car paintwork, please take care when mounting magnetic GPS antennas. In particular make sure that there are no dust or grit under the antenna. In some cases it may be required to add additional protection to the paintwork prior to mounting the antenna to avoid damage.

2.1 Identifying Your Unit

Several different versions of the DL1 have been released. For information on identifying your unit, please read the section 8.2

3 Installing the unit

3.1 Mounting

As the DL1 CLUB contains accelerometers, it is important that the unit is mounted on a flat, fairly level surface in the vehicle. A small amount of tilt can be compensated for in the software, however, large tilt angles cause loss of resolution and increased noise due to vertical vibration. For more information on configuring and zeroing accelerometers please read the following knowledgebase article:

<http://www.race-technology.com/wiki/index.php/Technical/ZeroingAccelerometers>

Just as importantly, the logger must be mounted "squarely" in the vehicle with the button facing towards the back of the vehicle. If the unit is mounted at an angle to the direction of travel for the vehicle, then the unit will be measuring longitudinal accelerations when you are cornering and vice versa. Acceleration errors caused by mounting the unit at an angle to the direction of travel cannot be compensated for, so it is important to get it right.

On most installations the unit will be mounted using 2 strips of scotch lock tape on the base of the unit. This is simple and secure and allows the unit to be moved quickly between different vehicles. If a more permanent installation is required then there are two main options available:

1. You can use either the mounting holes on the side of the unit. These are designed to take 2.9mm self tapping screws (No. 4) with a maximum penetration depth of 6.5mm.
2. Or a set of "hook in" brackets are available that fit into the channels on the sides of the case. They are made from brushed stainless steel, and are designed to be used with M4 screws or similar diameter self tapping screws (#7 or #8). The mounting diagram for these is shown on next page:

3.1.1 Bracket Mounting

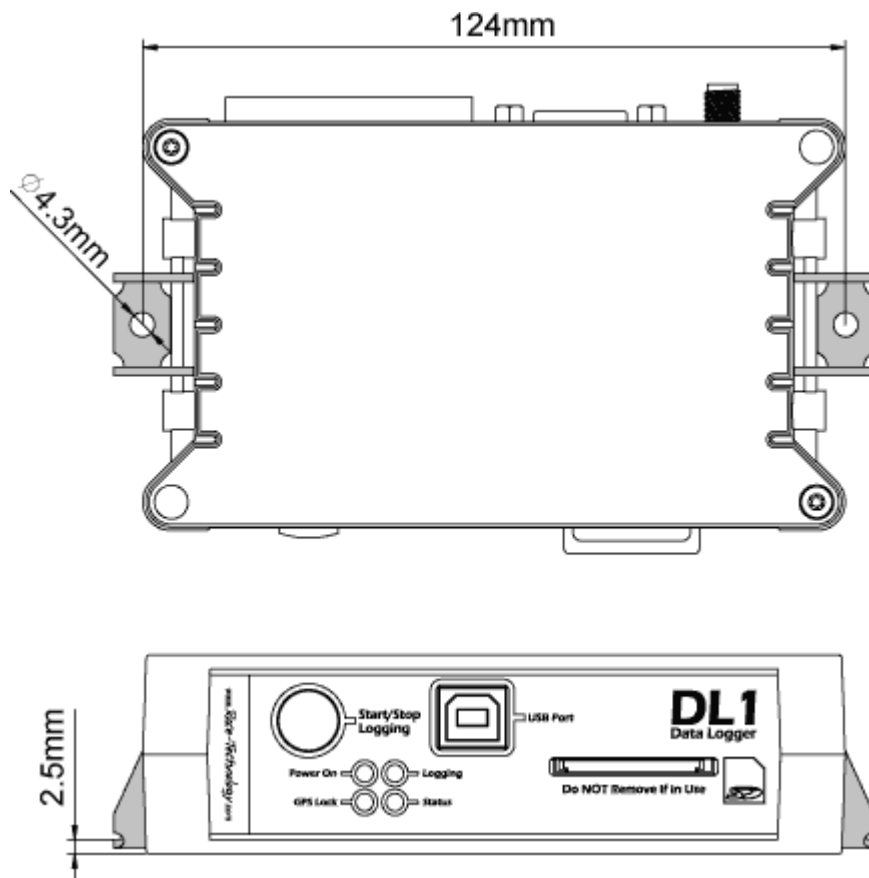

3.2 Power

The DL1 CLUB Unit is supplied with a cigarette lighter based power supply. The centre pin connects to +12V and the outer connects to the vehicle ground. This method is convenient if you are temporarily connecting the unit to the vehicle (typically on a road car).

If you want to permanently wire the DL1 CLUB Unit directly into the engine wiring loom, rather than using the cigarette lighter socket, then you must use a fused supply with a fuse rating of no more than 1 amp. It is also highly recommended that the unit has its own external power switch so it can be easily turned off. This is to prevent any draining of the battery, or any damage to the unit when the engine is turned on or when the car is being cranked over. It is recommended that you only turn the unit on once the engine is running. It is possible that leaving the DL1 CLUB turned on during cranking may corrupt the data in the logger.

Also please note that in all cases the GPS receiver is powered on whenever there is power to the main unit - it does not turn on and off with the main unit, so if the DL1 CLUB is left connected to the battery it will flatten it.

Alternatively, the DL1 CLUB can be powered from a separate battery if required - this is often appropriate for temporary installations where a cigar lighter is not available. The DL1 CLUB requires a minimum of 10v and draw about 100mA-200mA, so the size of the battery should be chosen to give sufficient run time. For example a 1Ah battery would give about 5 hours operation. Because of the current supply requirements only rechargeable batteries should be used, you cannot use disposable batteries. If you do require a battery pack, Race Technology keep a wide selection in stock - call us with your requirements.

Start the vehicle, wait a few seconds then connect the power lead to the unit. After a few seconds, the "Power" LED will come on and when the unit is ready to log the "status" light will flash. Wait for a few minutes to enable the GPS to obtain a good positional lock. Once the receiver has a lock, the GPS status light on the DL1 CLUB will start flashing.

3.3 Further reading

For more information, read the following sections:

- Fitting a cable to the black connector that is used to power the DL1 CLUB (section 8.7)
- Connecting a switch to start or stop the DL1 CLUB (section 8.4)

4 Quick Start Guide

This short guide is intended as a quick introduction to enable you to install the DL1 CLUB in a vehicle and log your first set of data. It is certainly not intended as a full set up guide. There are four sections to the quick start guide: Installing the DL1 CLUB into the vehicle, Default configuration, Logging some sample data and Looking at the data for the first time using the software.

4.1 Installing the DL1 CLUB in the vehicle

4.1.1 Mounting the DL1 CLUB in the vehicle

The DL1 CLUB should be mounted in the vehicle on a flat horizontal surface. For temporary installation you can just use the Dual-Lock™ tape supplied, or for a more permanent installation the mounting brackets. The DL1 CLUB must be mounted with the buttons and lights facing either directly towards the back or the front of the car. Avoid any extremes of temperature and vibration for both the DL1 CLUB module and the GPS antenna. In particular, if the DL1 CLUB is exposed to vibration then the GPS data will become inaccurate.

4.1.2 Correct Mounting of the GPS Antenna

"WARNING": To avoid any possible damage to the car paintwork, please take care when mounting magnetic GPS antennas. In particular make sure that there is no dust or grit under the antenna. In some cases it may be required to add additional protection to the paintwork prior to mounting the antenna to avoid damage.

For correct, accurate operation of the GPS receiver it is absolutely essential that the antenna is mounted correctly. There are several important aspects to consider when mounting the antenna:

- The antenna must have a clear view of the sky in all directions. Note that it is NOT enough that the antenna can see vertically upwards towards the sky, it must also be able to see all the horizons as well. The GPS system actually gets very little positional or speed information from the satellites directly above, it gets far more information from satellites on or near the horizon. For example if the antenna was mounted in the bottom of a "bucket", so it could upwards but no horizons, then the GPS system would lock and provide positional information - but the accuracy would be very poor. In practice this all means that the antenna should be mounted on the highest point of the vehicle.
- The antenna must be mounted on a horizontal surface. The antenna must be mounted on a horizontal orientation facing directly up. The underside of the antenna cannot receive GPS information, similarly don't mount the antenna on a vertical surface.
- The antenna must not be covered in tape, in particular dark coloured tapes. Many tapes absorb the weak GPS radio signal. In general, black tapes are the worst in

this respect as they contain high amounts of carbon - however, to be safe, avoid using any tape at all.

- The antenna must not be subjected to high levels of vibration. Although the antenna is physically robust to vibration, it can and does affect GPS reception, so isolate it as much as possible.
- The antenna must be physically remote from sources of electrical noise. The GPS radio signal is very weak and can easily be blocked out by radio interference, so to get a good signal the antenna must be as far away from radio interference as possible. By far the strongest source of radio interference is a gasoline engine's ignition system, so keep the antenna away from all aspects of it including the engine management system, coil, leads, distributor etc.
- Avoid trapping, pinching or kinking the antenna cable. The lead from the GPS antenna to the receiver is a special very high frequency cable and it is not normally practical to repair it - so if you do trap, pinch or cut it then the antenna will have to be replaced and this isn't covered by the warranty. Do not try to feed the antenna cable through a closure gap that is too small or compress it with a door seal or window seal.
- If at all possible, mount the antenna on a metal platform. The GPS radio signal is amplified if the antenna is mounted on a metal plate (termed a ground plane), and the bigger this plate is the better it will be for GPS reception. This is not essential for correct operation, but it is desirable.
- Allow time for the GPS system to lock on before sampling data. The GPS receiver typically takes one to two minutes to lock on to all the available satellites. The time to lock onto satellites varies significantly with conditions but is minimised when the vehicle is stationary.

4.1.3 Recommended mounting positions for the GPS antenna

- If the vehicle has a roof, this is the ideal place to mount the antenna.
- Alternatively, the best mounting position on a car may be the roll over bar or the top of the windscreen frame.
- On a motorbike, mounting is a little more difficult, but the best compromise is on a flat area of the tail unit, behind the rider.
- Poor mounting positions on a car include behind the front or rear windscreens.

Note: If you fail to adhere to the guidelines above, the GPS will still probably perform "adequately" "most" of the time, however when conditions are more challenging (with tree cover or bad weather etc) the positional accuracy will be significantly reduced.

4.1.4 Connecting the GPS module (if used)

Place the GPS antenna on the roof of the car, and screw the antenna connector onto the gold connector on the back of the DL1 CLUB.

4.1.5 Connecting the power cable

If there is a cigarette lighter socket available on the vehicle, then the power lead provided can be used as a simple convenient way to supply power to the DL1 CLUB. If not, connect the DL1 CLUB to a fused power source, which is available when the ignition is turned on. Connecting to a permanent power source will cause the DL1 CLUB to drain the battery continuously. Please do not connect anything to your car unless you are confident in what you are doing!

4.2 Default Configuration

The DL1 CLUB can be configured by direct connection to a PC through the USB port or by loading the configuration file on to the SD card which is put in to the unit. The unit has a default configuration from the factory. This configuration has the following settings for the analogue channels:

1. Spare input
 2. Fuel level
 3. Boost pressure
 4. Air temperature
 5. Oil pressure
 6. Oil temp
 7. Water temp
 8. Start / stop control
- If the output driver option is enabled, the port 12 is used as the status output.
 - Frequency inputs are set to map to wheel speeds 1-4, the high level RPM input is enabled.
 - All channels are transmitted on the serial port and all channels are logged to the SD card.
 - Automatic starting and stopping of logging are disabled.

If you need to change any of these configurations, start up the DL1 CLUB configuration software.

Full instruction on how to configure the unit can be found in the online help which is installed with the Analysis software package.

NOTE: The default configuration will need to be changed if the unit is used with an ECU interface, failure to change this will result in no readings for any of the channels listed above.

4.3 Logging data using the DL1 CLUB

4.3.1 Powering up the DL1 CLUB

Start the vehicle, wait a few seconds the "Power" LED will come on. Wait for a few moments while the GPS receiver acquires a good positional lock. Once the GPS has a lock, the GPS LED on the front of the DL1 CLUB will light up.

4.3.2 Insert an SD card

Take an SD or SDHC card and format it in the PC – the card must be formatted as "FAT32" formatting it as "NTFS" or any other file system will cause unexpected behaviour. When formatting is complete, remove the card and place it in the DL1 CLUB slot. Once it is inserted wait a few seconds and the status light should start flashing indicating that the DL1 CLUB is ready to start logging data. If the status light does not start flashing, power down the DL1 CLUB and repeat the above steps. If the status light does not flash on / off in equal measure then it could be one of the following problems:

1. SD Card detection error - one quick flash and off period
2. FAT file system initialize error – two quick flash and off period
3. SD card write error – three quick flash and off period
4. SD card read error – four quick flash and off period

4.3.3 Sampling data

To sample some data, simply press the "Start/stop logging" button on the front of the DL1 CLUB. After a short pause, the "Logging" LED will illuminate, indicating that data is being stored on the memory card. Drive the vehicle around for a while (slowly, safely and in a responsible manner). To stop sampling press the "Start/stop logging" button again. When you have stopped sampling data you can turn off power to the DL1 CLUB unit. Never remove the card from the DL1 CLUB whilst it is logging data. This can corrupt the card and the data will be lost.

4.4 Analysing data from the DL1 CLUB

Please note that the analysis software supplied with the DL1 CLUB is very powerful and flexible and in most cases there are several ways that the same information can be accessed or generated. This guide is intended to be a very brief introduction to the software to enable you to get up and running as quickly as possible. When you require more information, or find a problem carrying out any of the following procedures, please refer to the on line help system that comes supplied with the DL1 CLUB.

4.4.1 Installing the SD card reader

If required, install the SD card reader according to the manufacturer's instructions. On many laptop computers the card reader is already built in and the external reader is not required.

4.4.2 Installing the software on the PC

Before you can analyse the data from the DL1 CLUB you must install the software from the supplied CD onto your PC. When you insert the CD-ROM, the installation program should start automatically. Follow the onscreen instructions to install the software.

4.4.3 Loading the data into the software

To load the data from the SD card, remove the card from the slot in the front of the DL1 CLUB (after stopping logging) and place it in the card reader connected to your PC. The data files on the SD card will appear in Windows Explorer as “.run” files separated into directories named with the date on which they were recorded. Your test data file can either be opened by "double clicking" on a “.run” file, or alternatively you can start the software and go to "File" -> "Open". The data will now download – once it has done so, click “yes” when you are asked if you want to process the data.

4.4.4 Display the track map and a graph of speed for the entire run

To view a map of the current data that is loaded select the “Results” -> “Track map” menu, use the zoom button to navigate around the map. To display a simple graph of speed for the entire run, select the “Results” -> “Graph” menu, and under the “Setup” tab select “GPS Speed [mph]” as the first variable. Then click back on the “Graph” tab to view the data.

4.4.5 Display your acceleration and braking times.

To display a full table of the acceleration times go to the “Results” -> “Performance Calculations” menu and then select the “Timings” tab. A table of acceleration times extracted from the data will be generated automatically.

4.4.6 Displaying lap and sector times

The first stage of the process is to add a “lap marker” to the track map. This is done in the “track map” window by selecting the “add track marker” tool from the top right hand corner of the track map window and adding a marker across a section of the track. Next, go to the “Window” -> “Show Lap/Sector times” menu and you will be presented with a list of lap times in a spreadsheet style table. You can add and name sectors manually on the track map, but for this example we will add the markers automatically. To do this go to the “Data” -> “Laps and Sectors” menu, select the “Sector setup” tab and then click the “Automatically add sectors now” button. After a short pause, the sectors will be shown in the table. Close the “Lap and Sector options” dialog box. If you look at the track map you will see that a number of track markers and named sectors have been added, also if you check the “Lap and Sector Times” table, you will see that sector times are now displayed alongside the lap times.

4.4.7 Automatically generating a graph comparing speeds on two laps

You can automatically generate a graph showing the speeds for 2 laps most easily from the “Lap and Sector times” table. Simply select the lap times of interest on the “Lap and

Sector times” table, as they are selected the cells will turn red. After selecting the laps of interest, click the “graph” button at the top left hand side of the table. You will be prompted for the type of graph you wish to generate, select “Speed versus Distance” and click “Ok”. After a short pause a graph will appear with speed information for the laps selected.

5 Operating the DL1 CLUB

5.1 Description of the plug/connections/lights etc on the DL1 CLUB

F R O N T	Start/Stop Logging Button	Press once to start logging, again to stop logging.
	Status Light	<p>This light flashes to indicate that the DL1 CLUBs processor is operating normally and is ready to log data. In an error situation this LED blinks a number of times followed by an off period, as shown below.</p> <ul style="list-style-type: none"> ▪ 2 SD Card detection error ▪ 3 SD card write error ▪ 4 SD card read error ▪ 5 FAT file system initialize error ▪ 6 Over voltage error ▪ 7 Configuration error ▪ 8 Firmware error ▪ 9 License error ▪ 10 Serial number error ▪ 11 Calibration error ▪ 12 Board test error
	GPS Lock Light	<p>This light will be on when the GPS receiver has a lock. Details about mounting the GPS antenna are here: http://www.race-technology.com/wiki/index.php/Common/MountingAGPSAntenna</p>
	Power On	<p>This light illuminates when the DL1 CLUB is connected to a valid power supply. Advice about connecting a power supply is here: http://www.race-technology.com/wiki/index.php/Common/PowerSupplyRequirements.</p>
	Logging	<p>This light illuminates when the DL1 CLUB is actually logging data to the SD card. When this light is illuminated YOU MUST NOT TURN THE DL1 CLUB OFF, OR EJECT THE SD CARD!</p>
	SD card Slot	<p>This is the slot for the SD or SDHC card.</p>

R A R E	A1	Analogue input 1, for use with external sensors maximum input 25v.
	A2	Analogue input 2, for use with external sensors maximum input 25v.
	A3	Analogue input 3, for use with external sensors maximum input 25v.
	A4	Analogue input 4, for use with external sensors maximum input 25v.
	A5	Analogue input 5, for use with external sensors maximum input 25v.
	A6	Analogue input 6, for use with external sensors maximum input 25v.
	A7	Analogue input 7, for use with external sensors maximum input 25v.
	A8	Analogue input 8, for use with external sensors maximum input 25v.
	A9	Analogue input 9, for use with external sensors maximum input 25v. Low side driver output, maximum 0.5A
	A10	Analogue input 10, for use with external sensors maximum input 25v. Low side driver output, maximum 0.5A
	A11	Analogue input 11, for use with external sensors maximum input 25v. Low side driver output, maximum 0.5A
	A12	Analogue input 12, for use with external sensors maximum input 25v. Low side driver output, maximum 0.5A
	GND	Ground, recommended for grounding analogue sensors.
	Ground	Ground, recommended for grounding analogue sensors.
	+5v1	+5v output, maximum current output 0.5A. This can be used for powering external sensors
	+5v2	+5v output, maximum current output 0.5A. This can be used for powering external sensors
+12v Power	ESSENTIAL! This is the power supply for the DL1 CLUB, it needs 10v-15v and about 150mA minimum. Details here: http://www.race-technology.com/wiki/index.php/Common/PowerSupplyRequirements	
GND	ESSENTIAL! This is the ground for the power supply to the DL1 CLUB. Details here: http://www.race-technology.com/wiki/index.php/Common/PowerSupplyRequirements	
rL	This is the "low level" rpm input that triggers about 5v - this MUST NOT be connected to the ignition coil. Details here. http://www.race-technology.com/wiki/index.php/Common/ConnectingRPMSensors	
rH	This is the "high level" rpm input that connects to the low voltage side of the coil. Details here: http://www.race-technology.com/wiki/index.php/Common/ConnectingRPMSensors	

R A R E	rG	This is the ground for the "high level" rpm input that connects to an HT lead or the low voltage side of the coil. Details here: http://www.race-technology.com/wiki/index.php/Common/ConnectingRPMsensors
	F1	Frequency input 1, for connection to an external shaft or wheel speed. Triggers at 3v. Details here: http://www.race-technology.com/wiki/index.php/Common/AddingWheelSpeedSensors
	F2	Frequency input 2, for connection to an external shaft or wheel speed. Triggers at 3v. Details here: http://www.race-technology.com/wiki/index.php/Common/AddingWheelSpeedSensors
	F3	Frequency input 3, for connection to an external shaft or wheel speed. Triggers at 3v. Details here: http://www.race-technology.com/wiki/index.php/Common/AddingWheelSpeedSensors
	F4	Frequency input 4, for connection to an external shaft or wheel speed. Triggers at 3v. Details here: http://www.race-technology.com/wiki/index.php/Common/AddingWheelSpeedSensors
	GPS rf +3.3v	GPS antenna connection (gold SMA type). This feeds 3.3v out to the active GPS antenna and takes in the GPS rf signal.
	Data Port	This single connector actually connects to 2 serial ports and a CAN port. One of the serial ports is generally used to connect to a display unit, such as a DASH2, the other to an ECU interface.

"WARNING": To avoid any possible damage to the car paintwork, please take care when mounting magnetic GPS antennas. In particular make sure that there are no dust or grit under the antenna. In some cases it may be required to add additional protection to the paintwork prior to mounting the antenna to avoid damage.

5.2 Sampling Data with the DL1 CLUB

- If used, connect a GPS antenna to the rear of the DL1 CLUB.
- Connect the DL1 CLUB to a valid power supply. After a short pause the power light on the front of the unit will come on and the status light will start flashing rapidly.
- Insert a freshly formatted SD card into the slot, the status light will stop flashing for a second or 2 then start again when the DL1 CLUB is ready to log data.
- Press the "Start/Stop Logging" button on the front of the DL1 CLUB, the "Logging" light will come on indicating that the DL1 CLUB is writing data to the SD card.

5.2.1 To stop data logging:

- Press the Start/Stop Logging button on the front of the DL1 CLUB; the "Logging" light will go out.
- ONCE THE LOGGING LIGHT HAS GONE OUT, eject the SD card from its slot. Power can now be disconnected if required.
- Put the SD card in a suitable reader and check a file has been written to it.

5.2.2 Advanced operation

You can set the DL1 CLUB to automatically start and stop logging based on external inputs or on a timed basis. For more information on how to do this, see the DL1 CLUB Configuration software section:

<http://www.race-technology.com/wiki/index.php/Configuration/DL1MK3Configuration>

5.3 Real Time Output

Practically the whole time the DL1 CLUB is powered up, it is outputting data in real time to the external serial port. This can be used for a number of applications including monitoring the data on a PC or streaming to a dashboard or video logger.

5.4 Further Reading

For more information on operating the unit, please read on the following sections:

- Manually Commencing Logging (section 8.1)
- Automatic Logging Control

<http://www.race-technology.com/wiki/index.php/DL1MK3Configuration/AutomaticLoggingControl>

6 Connecting external sensors to the DL1 CLUB

6.1 Connecting GPS

For the DL1 CLUB, the GPS antenna comes with 3 metre cable, which will allow you to position the module almost anywhere on a road car. The GPS antenna connects via a co-axial screw connector on the back of the DL1 CLUB Unit. Once the GPS antenna has been connected, it will turn on automatically when there is power to the DL1 CLUB unit.

The best place to position the GPS antenna will change depending on the vehicle type. The GPS needs a good clear view of the sky to be able to lock onto the satellites to give the best results. As such, if there is a roof to the vehicle, this will always be the best place to place the antenna. If you are on a vehicle like a kart or a bike, then you will have to find the best location which gives a constant view of the sky.

For more detailed information on GPS antenna positioning read the following knowledgebase article:

<http://www.race-technology.com/wiki/index.php/Common/MountingAGPSAntenna>

Please note that if your GPS antenna gets damaged, you can buy a replacement antenna from Race Technology. Email sales@Race-Technology.com for further details if you need a replacement antenna.

"WARNING": To avoid any possible damage to the car paintwork, please take care when mounting magnetic GPS antennas. In particular make sure that there are no dust or grit under the antenna. In some cases it may be required to add additional protection to the paintwork prior to mounting the antenna to avoid damage.

6.2 External Sensors

The DL1 CLUB allows you to attach several external sensors for logging. These can be frequency or analogue inputs. There are 4 frequency inputs, generally used for shaft or wheel speeds, and 12 analogue channels (25v input). The DL1 CLUB is supplied with connectors for the external inputs. For each input, the positive wire connects to the input, and the ground to one of the ground connectors. If the sensor needs a 5v reference supply, there are two available on the back of the unit. You can have more than one sensor attached to the ground and reference output.

If you wish to connect an RPM sensor, see here for more details:

<http://www.race-technology.com/wiki/index.php/Common/ConnectingRPMsensorsThe>

25v input is a nominal maximum, exceeding this upper voltage limit will cause other channels to read incorrect voltages.

6.3 Connecting A wheel speed sensor

Allow a few hours to mount and test the wheel speed sensor correctly, there is no simple/universal solution to fitting the wheel speed pickup and in some applications it can be problematic. The wheel speed sensor supplied by Race Technology is a high quality "Hall Effect" type, it is the same type of sensor that is used in high quality ABS and traction control systems on high performance production cars. This type of sensor does not require a magnet to trigger it, just something metal - typically, the sensor is mounted so it is pointing at a moving bolt head. The sensor should be rigidly mounted using the bolt hole through the sensor and with the end less than 3mm from the moving metal object. The closer to the metal object the sensor is mounted, the better the slow speed performance of the sensor. There are 3 wires connected to the wheel speed sensor: (<http://www.race-technology.com/wiki/index.php/Common/AddingWheelSpeedSensors>)

- The black wire that should be connected to the ground terminal of the DL1 CLUB
- The red wire that should be connected to the +5v output of the DL1 CLUB
- The white wire that should be connected to the wheel speed input (one of the frequency inputs) of the DL1 CLUB

6.4 Remote start/logging indicator

The DL1 CLUB has the option to have an external start/stop logging switch and an external indicator fitted. There are no dedicated pins on the DL1 CLUB to do this. It is done by using one of the analogue inputs as the logging control input and one of the low side driver outputs (Analogue 9-12) as the logging status output.

- Connect a momentary switch between Analogue input 11 and one of the 5v references. This will put a 5v pulse on the analogue input which will trigger the start/stop.
- Connect the - terminal of an indicator lamp / LED to Analogue input 12 and the + terminal to either one of the reference outputs or to the main 12v supply.

This means that not only can you start and stop the logging remotely, you can also monitor whether the device is currently logging - useful when the DL1 CLUB unit is mounted in a position that cannot be seen from the driver's seat.

7 DL1 CLUB Connector details

7.1 Rear View

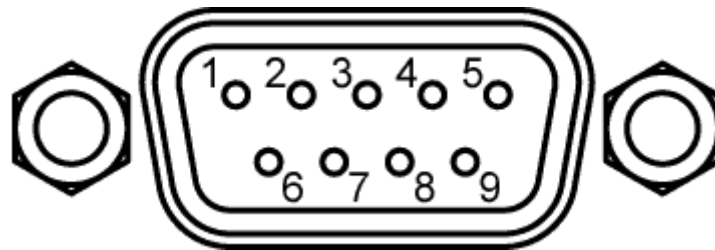

PIN	DESCRIPTION
1	CAN L - Low connection for CAN interface
2	RX1 - Serial port 1 Data In
3	TX1 - Serial port 1 Data Out
4	TX2 - Serial port 2 Data Out
5	GND
6	RX2 - Serial port 2 Data In
7	+12v Out (250 mA limit)
8	CAN H - High connection for CAN interface
9	N/C

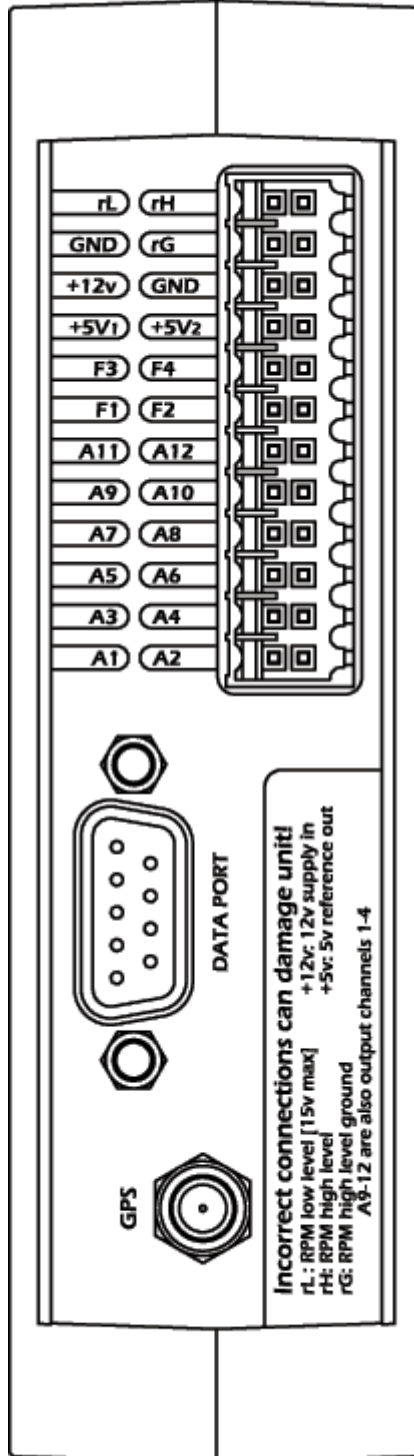

LABEL	DESCRIPTION	
A1	0-25v 12-Bit analogue input	In
A2	0-25v 12-Bit analogue input	In
A3	0-25v 12-Bit analogue input	In
A4	0-25v 12-Bit analogue input	In
A5	0-25v 12-Bit analogue input	In
A6	0-25v 12-Bit analogue input	In
A7	0-25v 12-Bit analogue input	In
A8	0-25v 12-Bit analogue input	In
A9	0-25v input, low side output 0.5A Max	In/Out
A10	0-25v input, low side output 0.5A Max	In/Out
A11	0-25v input, low side output 0.5A Max	In/Out
A12	0-25v input, low side output 0.5A Max	In/Out
rL - RPM Low Level	5-15v Trigger - ECU or Tacho Use.	
GND	System and sensor ground	
rH - RPM High Level	1KHz HT Input - more info here: http://www.race-technology.com/wiki/index.php/Common/ConnectingRPMSensors	In
rG - RPM High Level Ground	more info here – http://www.race-technology.com/wiki/index.php/Common/ConnectingRPMSensors	In
F1	100K? Pull Down Included. 5-12V I/P >2KHz Max.	In
F2	100K? Pull Down Included. 5-12V I/P >2KHz Max.	In
F3	100K? Pull Down Included. 5-12V I/P >2KHz Max.	In
F4	100K? Pull Down Included. 5-12V I/P >2KHz Max.	In
+5v ₁	500mA Max reference output	Out
+5v ₂	500mA Max reference output	Out
+12v	9-24v power input	In
GPS RF +3.3v	GPS Antenna Connection (3.3v)	

"WARNING": To avoid any possible damage to the car paintwork, please take care when mounting magnetic GPS antennas. In particular make sure that there are no dust or grit under the antenna. In some cases it may be required to add additional protection to the paintwork prior to mounting the antenna to avoid damage.

When the CAN interface or second serial port options are ordered for the DL1 CLUB the following breakout cable will also be supplied, to enable easy connection:

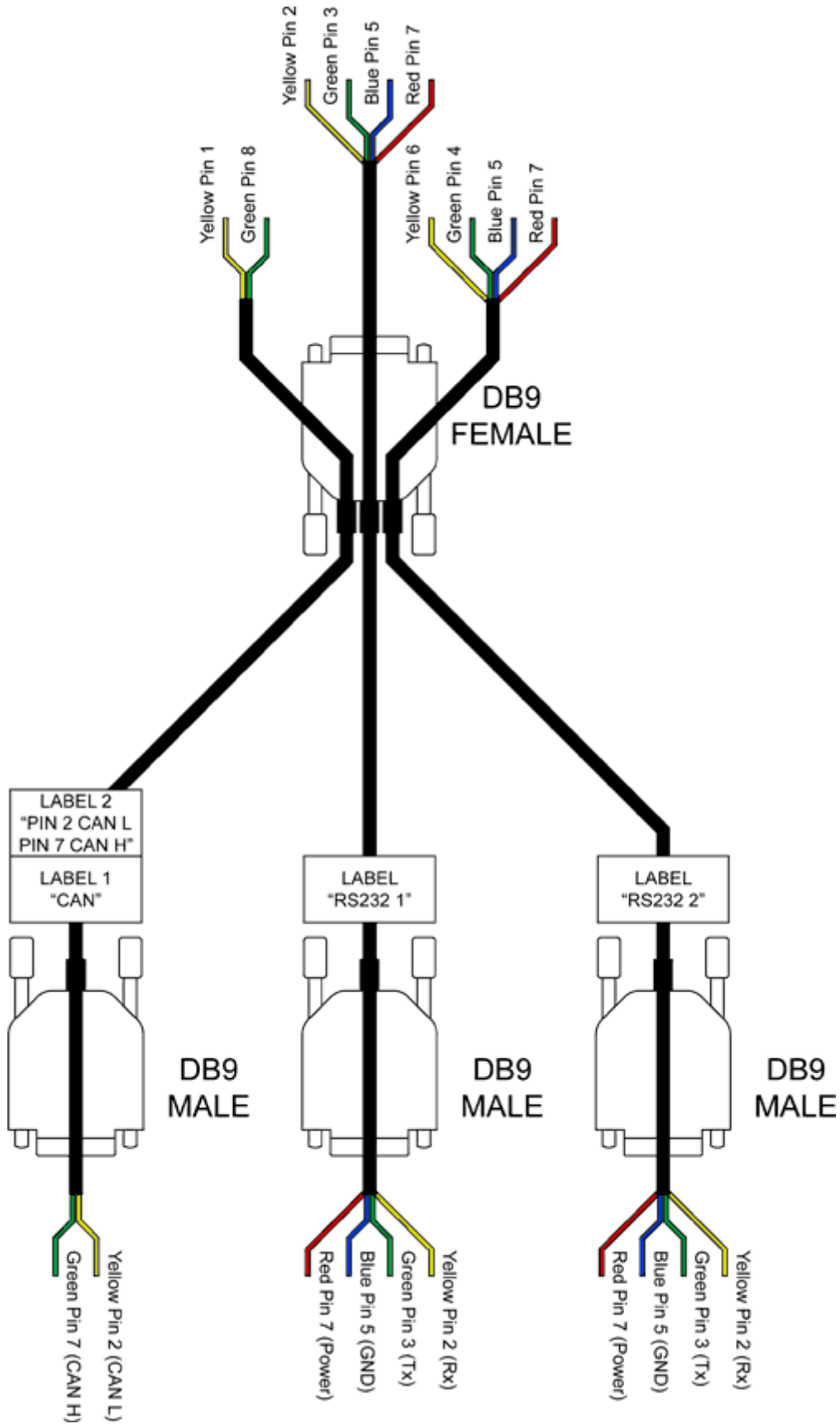

8 How Do I?

8.1 How do I manually start and stop logging on my DL1 CLUB?

When the DL1 CLUB is not logging, the “logging” LED will not be illuminated. Make sure that the status LED is flashing, this indicates that the unit has a valid memory card inserted and is ready to start logging. If the LED is not lit, check that the memory card is not full and is correctly formatted.

Press the Start/Stop Logging button. The Logging LED will illuminate and logging will start. To stop the logging press the button again.

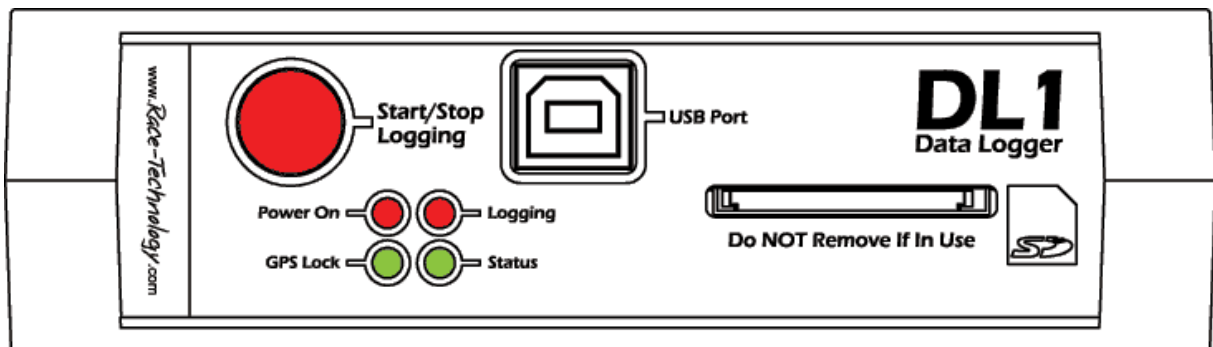

8.2 How do I know what kind of DL1 I have?

There have been four different editions of the DL1 issued to date. For your application, it may be important to know which edition you have:

8.2.1 The early DL1 Mk1



- Orange, 2-piece, single row, rear connectors
- Serial connector on the front
- No power supply on the serial port

If you wish to use this type of DL1 with an ancillary unit connected to the serial port (DASH1, VOB, ECU Interface etc.), it must first be returned to Race Technology for a small modification to connect power to the serial port.

8.2.2 The later DL1 Mk1



- Green, 2-piece, single row, rear connectors
- Serial port on the front
- Power supply provided on the serial port

8.2.3 The DL1 Mk2



- Black, 1-piece, double row, rear connector
- Serial port on the rear
- Power supply provided on the serial port

8.2.4 The DL1 MK3/CLUB



- Plastic case
- USB socket on the front
- SD card instead of CF card slot

8.3 Load a licence file

When you purchase optional additional features for your DL1 CLUB you will be sent a licence file via email. This licence will be in the form of a file called “licence.zip” which should be loaded onto your DL1 CLUB as follows:

1. Firstly, please format the SD card for your DL1 CLUB using Windows Explorer or Race Technology Analysis Software. Use FAT32 format
2. Next, double click on the “licence.zip” file to unzip it. Copy the licence.dat file within directly onto your SD card. Do not put the licence.dat file inside a folder. It must be on the “root” level of the card for the DL1 CLUB to read it
3. Now place the SD card into the slot in the DL1 CLUB
4. Turn on the power supply to the DL1 CLUB
5. Wait for 30 seconds while the DL1 CLUB reads the licence.dat file and saves its new settings. During this time the lights on the front of the unit will all illuminate, then the power light will remain illuminated and the status light will flash once per second
6. After 30 seconds you may remove the SD card from the DL1 CLUB
7. Please check the SD card on your computer. You should find that a folder called “DONE” has been created on the SD card, with the licence.dat file inside it. This confirms that the licence has been loaded onto your DL1 CLUB
8. Please reformat the SD card again. Use FAT32 format
9. Now turn off the power to your DL1 CLUB, then turn it on again
10. This concludes the upgrading of your DL1 CLUB. It is now ready for use

Please note: If you have purchased the 20Hz GPS upgrade you will also need to load a separate licence file onto your PC, following the instructions provided with this second licence file (codes.zip / codes.bin).

8.4 How do I connect a start/stop switch with indicator?

To connect a start/stop switch, wire as shown in the diagram below:

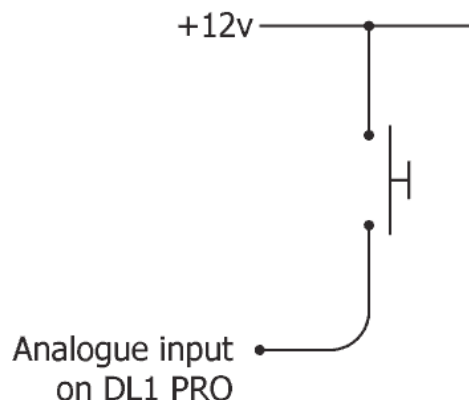

The "start/stop" button gives the driver the option of starting/stopping logging manually. Unlike the sensors that may be connected to the DL1 CLUB, the start/stop button has three connecting wires, and needs to be connected differently.

Step 1: Connect the wires on the start/stop button to the black, block connector that is on the end of the DL1 CLUB power cable. Once the block connector is plugged into the back of the DL1 CLUB, the orange writing on the unit will tell you where to put the wires:

- Red should be connected to 12v
- Green should be connected to 12v
- Blue should be connected to A12
- Yellow should be connected to A8

Step 2: The DL1 CLUB will need to be configured to use Analogue 8 as the trigger input, and to use Analogue 12 as the status output. For instructions on how to do that see here:

- Configuring inputs on the DL1 CLUB

<http://www.race-technology.com/wiki/index.php/DL1MK3Configuration/AnalogueInputs>

- Configuring output drivers on the DL1 CLUB

<http://www.race-technology.com/wiki/index.php/DL1MK3Configuration/OutputDrivers>

Once the button is properly connected, test that it is working. A red LED should light up in the buttons' centre to show when the unit is logging.

8.5 Connect and set up a GoPro interface cable

There are two wires on the GoPro interface cable, these need to be connected up as shown here:

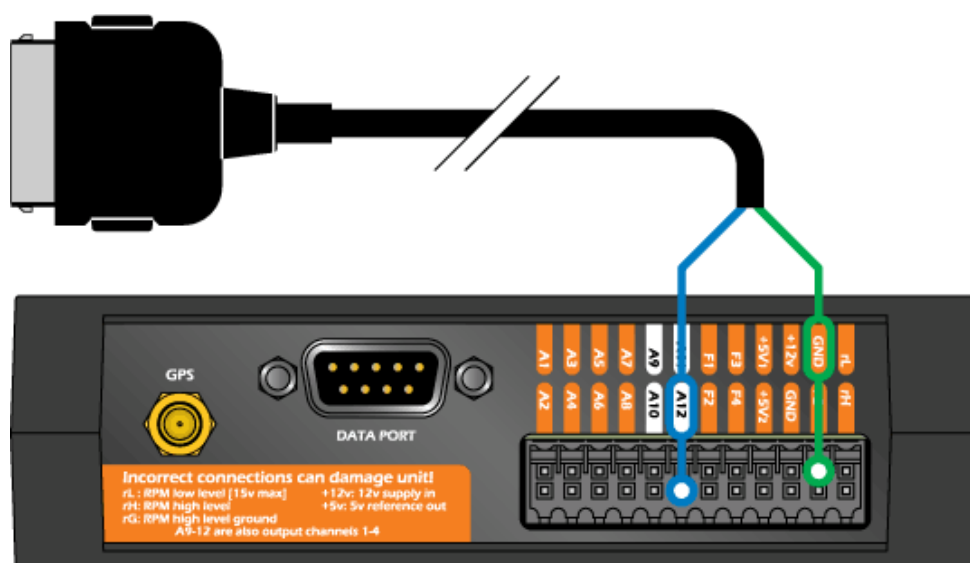

The GoPro must be set up in "1 button mode" so when it turns on it begins recording automatically.

After connecting up the cable the configuration software will need to be changed to set the status output up correctly.

Using the DL1 MK3/CLUB configuration software, select "Output Drivers" and enable GoPro Status on output 4:

Output driver	Control variable	Custom formula	Trigger value	Active above	Active below	Minimum time [s]	0% Value	100% Value	Frequency [100-1000Hz]	Enable PWM	Enabled/Disabled
01	analog 1 (Analogue input 1)		0	<input checked="" type="radio"/>	<input type="radio"/>	0	0	0	100	<input type="checkbox"/>	<input type="checkbox"/>
02	analog 2 (Analogue input 2)		0	<input checked="" type="radio"/>	<input type="radio"/>	0	0	0	100	<input type="checkbox"/>	<input type="checkbox"/>
03	analog 3 (Analogue input 3)		0	<input checked="" type="radio"/>	<input type="radio"/>	0	0	0	100	<input type="checkbox"/>	<input type="checkbox"/>
04	GoPro status		0.5	<input checked="" type="radio"/>	<input type="radio"/>	0	0	0	100	<input type="checkbox"/>	<input checked="" type="checkbox"/>

8.6 How do I connect a logging indicator?

To connect a logging indicator, wire up as shown in the diagram below:

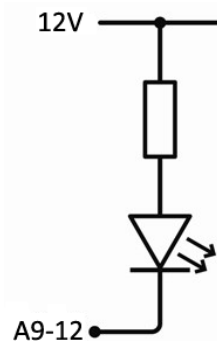

As well as wiring up the LED, the DL1 CLUB will need to be configured to use one of the low side driver outputs as a status output. See here for more information:

<http://www.race-technology.com/wiki/index.php/DL1MK3Configuration/OutputDrivers>

8.7 How do I fit a cable to the black connector that is used to power the DL1 CLUB?

Select a small, flat bladed, screwdriver.

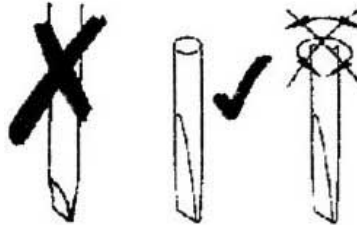

Insert the end of the screw driver into the square aperture, underneath the hole into which you wish to fit the wire. You will need to push the screw driver in quite firmly.

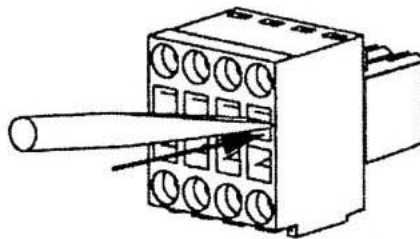

With the screwdriver still in place, insert the stripped and tinned end of the wire.

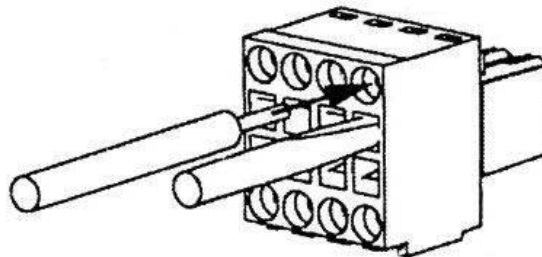

Now remove the screwdriver, leaving the wire to be gripped in place.

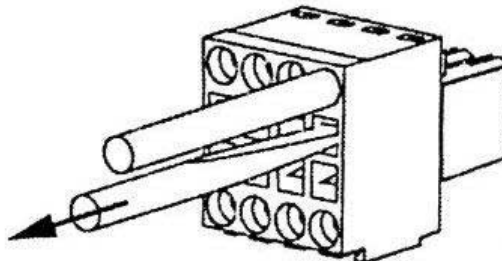

8.8 How do I connect a 1 or 2 wire sensor to the DL1 CLUB

The DL1 CLUB requires a voltage input on its sensor inputs that goes from a minimum of 0v to 12v maximum.

For sensors with 3 wires, typically you have:

- voltage supply
- 0v or ground
- signal out

Note that in some cases the ground connection maybe via the body of the sensor in which case there will only be 2 wires coming out of the actual sensor - however this is relatively unusual.

In this case the signal out can be connected directly to the one of the analogue inputs on the DL1 CLUB.

For sensors with 1 or 2 wires, it is slightly more complicated.

For a sensor with 2 wires it is typically a variable resistor with both ends of the resistor available:

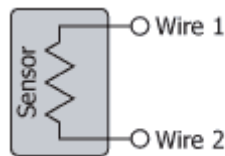

In this case we need to use a "pull up" resistor to convert the changing resistance to a changing voltage:

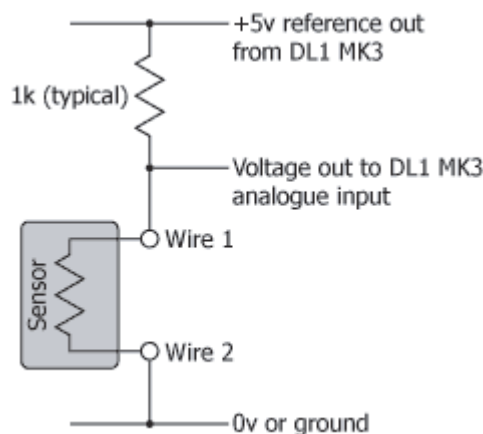

1 wire sensors are the same, but in this case the 2nd wire on the sensor is ground and made via the sensor body earthing to the engine casting etc.

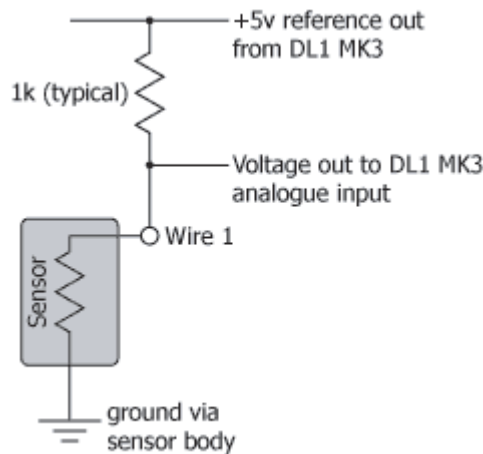

Once the sensor is connected to the DL1 CLUB with the pull up resistor then it can be calibrated in the normal way. For more information on this, please refer to this section.
<http://www.race-technology.com/wiki/index.php/HowDoI/ConnectMyOwnSensor>

8.8.1 Choosing a value for the pull up resistor

Please note that it is the installer responsibility to choose the correct value of “pull up” resistor when using 1 or 2 wire sensors with Race Technology products. For a particular sensor type there is no “correct” value of resistor however it must be selected to be “somewhere near” to ensure:

- There is a reasonable voltage swing, ideally this wants to be a “few volts” rather than a few “milli volts”. A small signal can get easily lost in “noise”.

You cannot take too much current from the 5v reference output, depending on the product typically this cannot be more than a total of 100mA.

The table below gives a indication of suitable pull up resistor values:

Sensor	Pull up resistor	Notes
100 ohms or lower (typical for low cost/quality VDO sensors)	100 ohms	With such a low pull up resistor you will only be able to have a maximum of 2 sensors before you use 100mA
Between about 100 ohms to 500 ohms	Between about 100 ohms to 500 ohms	
Between about 500 ohms to “a few” kilohms	1 kilohm (1k)	This is the normal setup for Race Technology Supplied sensors
Between “a few” kilohms and “a few” 10’s kilohms	10 kilohm (10k)	

8.9 How do I read data from my ECU and display it on my DASH1/DASH2 or log it on my DL1 CLUB?

To do this, you will require a Race Technology ECU interface.

Over recent months we have developed a wide range of ECU interfaces, that are compatible with various models of ECU used in the modern, automotive industry.

Some of our interface units are currently going through Beta testing, whilst others are in the development stage.

Please do not hesitate to contact the Race Technology sales department to check the availability of our units for the make and model of your ECU.

You can contact us on: **+44 (0)1773 537620** or email us at: sales@race-technology.com

8.10 Log DASH2 Analog Inputs

This section explains how to configure the DL1 CLUB to receive DASH2 analogue channels

1. Configuring the DL1 CLUB to expect the messages on the serial port
 - Open the DL1 CLUB configuration software
 - If you already have a configuration for the DL1 CLUB, load in the relevant configuration.
 - Click on the 'Variable Mapping' tab.
 - Set Analog 17-20 to be from Serial Port 1 Only:

Variable	Serial port 1 only	Serial port 2 only	Any serial port	Take from units built in inputs and sensors	Calculate from a combination of inputs using equation	Custom equation
analog 8	<input type="radio"/>	<input type="radio"/>	<input checked="" type="radio"/>		<input type="radio"/>	
analog 9	<input type="radio"/>	<input type="radio"/>	<input checked="" type="radio"/>		<input type="radio"/>	
analog 10	<input type="radio"/>	<input type="radio"/>	<input checked="" type="radio"/>		<input type="radio"/>	
analog 11	<input type="radio"/>	<input type="radio"/>	<input checked="" type="radio"/>		<input type="radio"/>	
analog 12	<input type="radio"/>	<input type="radio"/>	<input checked="" type="radio"/>		<input type="radio"/>	
analog 13	<input type="radio"/>	<input type="radio"/>	<input checked="" type="radio"/>		<input type="radio"/>	
analog 14	<input type="radio"/>	<input type="radio"/>	<input checked="" type="radio"/>		<input type="radio"/>	
analog 15	<input type="radio"/>	<input type="radio"/>	<input checked="" type="radio"/>		<input type="radio"/>	
analog 16	<input type="radio"/>	<input type="radio"/>	<input checked="" type="radio"/>		<input type="radio"/>	
analog 17	<input checked="" type="radio"/>	<input type="radio"/>	<input type="radio"/>		<input type="radio"/>	
analog 18	<input checked="" type="radio"/>	<input type="radio"/>	<input type="radio"/>		<input type="radio"/>	
analog 19	<input checked="" type="radio"/>	<input type="radio"/>	<input type="radio"/>		<input type="radio"/>	
analog 20	<input checked="" type="radio"/>	<input type="radio"/>	<input type="radio"/>		<input type="radio"/>	
analog 21	<input type="radio"/>	<input type="radio"/>	<input checked="" type="radio"/>		<input type="radio"/>	
analog 22	<input type="radio"/>	<input type="radio"/>	<input checked="" type="radio"/>		<input type="radio"/>	
analog 23	<input type="radio"/>	<input type="radio"/>	<input checked="" type="radio"/>		<input type="radio"/>	
analog 24	<input type="radio"/>	<input type="radio"/>	<input checked="" type="radio"/>		<input type="radio"/>	
analog 25	<input type="radio"/>	<input type="radio"/>	<input checked="" type="radio"/>		<input type="radio"/>	
analog 26	<input type="radio"/>	<input type="radio"/>	<input checked="" type="radio"/>		<input type="radio"/>	
analog 27	<input type="radio"/>	<input type="radio"/>	<input checked="" type="radio"/>		<input type="radio"/>	
analog 28	<input type="radio"/>	<input type="radio"/>	<input checked="" type="radio"/>		<input type="radio"/>	

If you wish to take RPM data from the DASH2, scroll up and set the RPM to also come from the same serial port. If the option is greyed out for taking RPM data from the serial you will first need to disable the internal RPM sensor on the DL1 CLUB.

2. Set the storage rate for the data on the Flash Card Storage tab.

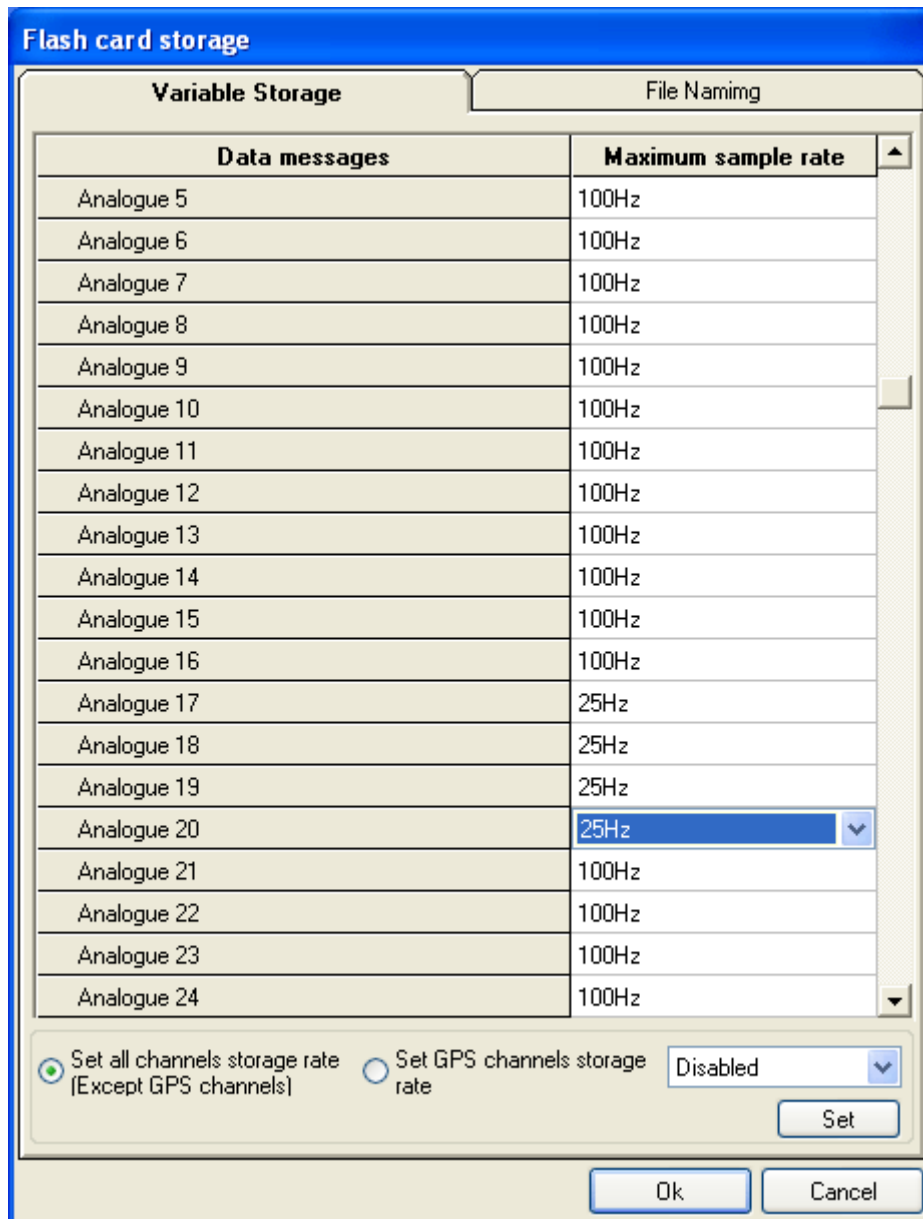

3. Save the configuration file and transfer it to the DL1 CLUB.

8.11 Why won't my DL1 CLUB work?

There may be a number of reasons why the DL1 CLUB will not start logging. You should check for the following things:

- Is your SD card full?
- Is your SD card correctly formatted? (It must be FAT, FAT32 or FAT16, and NOT NTFS)
- Is the Status LED flashing on the front of the unit
- Is the unit configured to automatically start/stop logging?
- Has your SD card been dropped/damaged/exposed to high temperatures?

These are the most common faults. If you have eliminated these, and your DL1 CLUB will still not log, please visit the support page on the website for further advice:
<http://www.race-technology.com>

8.12 Connect an RPM input

The high level RPM input on the DL1 CLUB can be used to connect to the negative terminal of an ignition coil. The rH terminal must be connected to the negative side of the coil and rG should be connected an earth. rL is not used.

- To configure the DL1 CLUB for the RPM input, start the configuration software and go to the RPM inputs tab.

Channel name	Maximum rate of change [RPM per second]	Smoothing filter time [seconds]	Pulses per revolution	Enabled/Disabled
High RPM	0	0	1	<input checked="" type="checkbox"/>
Low RPM	0	0	1	<input type="checkbox"/>

- Enable the High RPM input, set the number of pulses per revolution, depending on the ignition system you are using. If you are having issues with noise on the signal you can also set filtering for smoothing and maximum rate of change here.
- Click on the Flash Card Storage tab and set the speed at which the RPM input will be logged to the memory card.

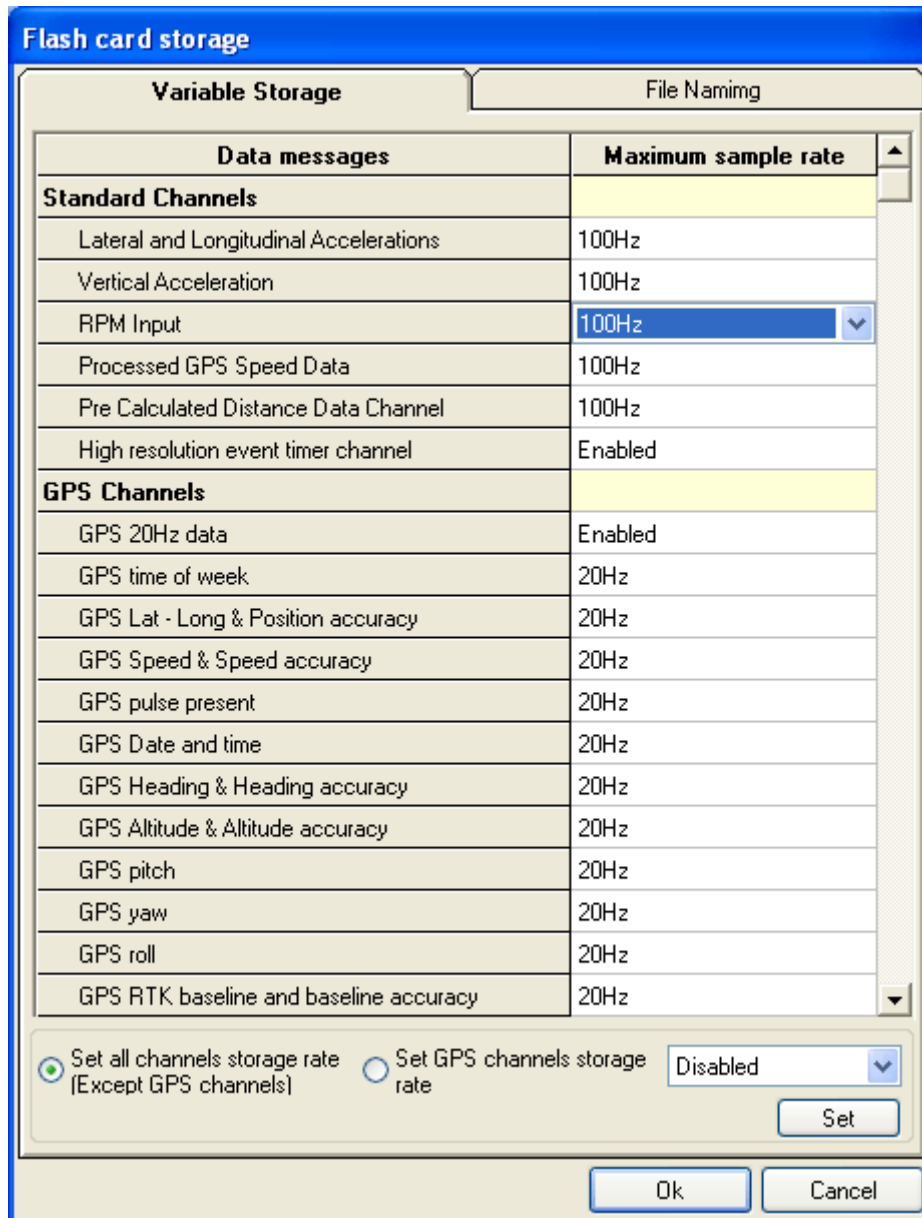

- If you are using the serial output of the DL1 CLUB to drive a dashboard or other display, also set up the output rate for the Output Serial Data tab in the same way.
- Save the configuration file and load it on to the DL1 CLUB.

8.13 How do I find out why my logger stopped logging during a race?

Step 1: Load up the data that was logged into the analysis software, and enter the "Run Manager" feature in the data menu (this can be found in the top, left hand corner of the screen).

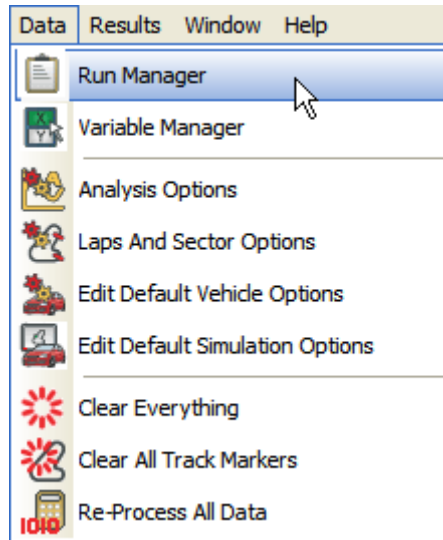

Step 2: this will open up a window. At the bottom of the window, under the heading "Run Details", you will find a breakdown of the details of the run. The reason why the unit stopped logging data will be stated at the end of this breakdown. In this example, the stop logging button was pressed.

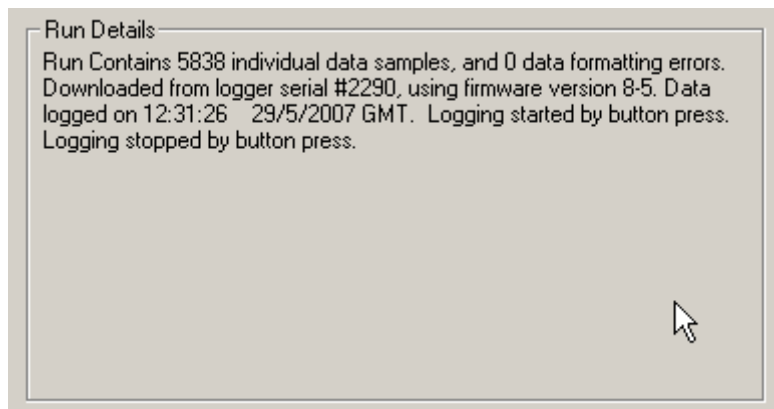

9 Frequently Asked Questions

9.1 What is the difference between the DL1 MK3/CLUB and the DL1 MK1/2?

The DL1 MK3/CLUB is a complete redesign of the DL1. It uses the same GPS receiver, accelerometer, and gyro, but pretty much everything else has been changed. It now operates with SD card instead of CF, it has a much more powerful processor, more analogue inputs, output drivers, dual serial ports.

Specification	DL1 MK2	DL1 MK3/CLUB
GPS	5Hz, 20Hz optional	5Hz, 20Hz optional
Analogue inputs	8	12*
Frequency inputs	4	4
Accelerometers	3 axis	3 axis
Serial ports	1	2
CAN ports	0	1
USB ports	0	1
6G accelerometer option	yes	yes
Input voltage	10-15v	9-24v
Reference output	5v 50mA	5v 500mA x 2
Output drivers	0	0.5A low side driver x 4 *
Memory card	Compact Flash, up to 1GB	SD or SDHC, up to 32GB
Enclosure	Extruded aluminium with carbon fibre front and back panels	Injection moulded ABS with polycarbonate front and back panels
Auto start / stop	Limited to analogue inputs and speed	Can use any channels of data
RPM input	High and low level inputs	High and low level inputs
Gyroscope	Optional	Optional

*Some features share pins on the connector, so not all can be used at the same time.

*Not all features are standard

9.2 What is the maximum g-force/speed that can be measured?

The standard DL1 CLUB is configured for a maximum of 2g acceleration, 6g is a factory option. The maximum measurable speed is about 1000mph.

9.3 How often do you get GPS speed updates?

The GPS system calculates speed every 200ms (5 Hz), however this data is combined with the data from the accelerometers to calculate speed 100 times every second with very high accuracy.

9.4 How often do you get GPS position updates?

The GPS system calculates position every 200ms (5 Hz), however this data is combined with the data from the accelerometers to calculate position 100 times every second with very high accuracy.

9.5 How accurately is speed measured?

With average GPS reception, speed accuracy is about 0.1mph (or 0.1% if greater) when you are just driving along at fairly constant speed, and about 0.2mph (or 0.1% if greater) during fast accelerations or braking. The only exception is at very low speeds (under 10mph) where the error increases to about 1mph. Do not be fooled by exaggerated claims from other manufacturers... this is as good as it gets! In contrast, a standard wheel speed pickup is only accurate to about 4% at constant speeds, and under high accelerations or braking, the error increases up to about 20%.

9.6 How accurately is position measured?

With good GPS reception, positional accuracy is about 3m (CEP).

9.7 What happens to the data if you drive under a bridge/tunnel/trees etc?

Because speed and position are calculated from both the GPS data and accelerometers, even if the GPS data “disappears” for a number of seconds, you won’t be able to tell from the data in the software. Only if GPS data disappears for an extended time (20+ seconds) will the data start to degrade noticeably.

9.8 Where can I buy it?

Check <http://www.Race-Technology.com> for an up-to-date list of stockists

9.9 Is it upgradeable?

The DL1 CLUB is upgradeable in a number of ways; please check <http://www.race-technology.com> for an up-to-date list of options. Software and firmware updates, including new features, are freely available as we introduce them.

9.10 How much data can you log to an SD card?

The DL1 CLUB logs about 25MB of data per hour, so for a 8GB card you could get up to about 2 weeks of data

9.11 Will it work with any SD card?

Whilst we cannot guarantee that the DL1 CLUB works with all SD and SDHC cards, we have successfully tested many makes and sizes of SD cards, we haven't yet found one it won't work with.

9.12 Is it easy to use?

The DL1 CLUB has one button to start and stop logging, how much simpler could we have made it? We have kept the software as simple as possible whilst making it as flexible as we can to ensure that you can do what you need to with it. As with all computer programs, the first time you use it there is a lot to take in - after you've become familiar with it, you will be able to analyse data quickly and efficiently.

9.13 What specification of computer is required?

As with most programs, the analysis software will run on just about any PC with windows 2000 or later – however, the faster the PC, the faster the program will run. The main restriction is the memory required for long runs; typically we recommend that your PC has an absolute minimum of about 30MB of memory installed for each hour of data loaded. The PC also requires some means of downloading the data from the SD cards, there are many options available – normally a USB reader is most convenient.

9.14 Is the DL1 CLUB reliable and well made?

The DL1 CLUB is absolutely class leading in terms of component quality, build quality and reliability – this is a very high quality professional instrument, entirely designed in-house and manufactured in England. The unit carries the normal 12 month guarantee against manufacturing defects.

9.15 What options does my DL1 CLUB have installed?

To find this, open the DL1 CLUB configuration software, connect to the DL1 CLUB through the USB port in the usual way to read the configuration data, then go to Options / Logger options. The list of available and enabled options will be displayed:

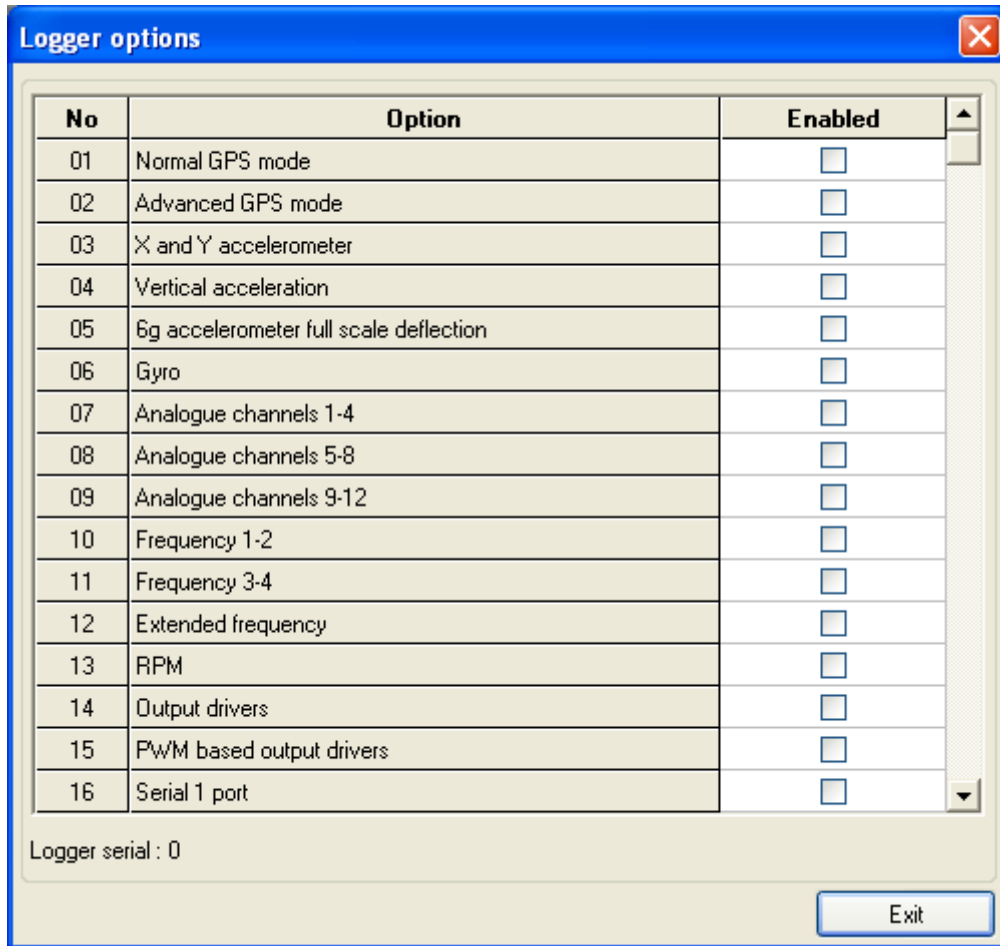

9.16 Can I add extra options to my DL1 CLUB?

All options except for the Gyro can be added by a software update file. If you wish to purchase any options please visit our website for the list of options and prices.

http://www.race-technology.com/dl1_2_27.html

10 DL1 CLUB Software

10.1 The Analysis Software

The analysis software is the main package that is supplied with all Race Technology products capable of logging data. The analysis package is used to load, view and analyse the data using a variety of tools.

<http://www.race-technology.com/wiki/index.php/Software/MainAnalysisSoftware>

10.2 The Realtime Monitor

The realtime monitor software is intended to view the serial output of our products in real time. The monitor software is particularly useful for checking that the hardware is installed correctly, and that all the signals are operating correctly.

<http://www.race-technology.com/wiki/index.php/Software/Monitor>

10.3 The Lite Monitor

The Lite Monitor can be used to display live serial data from a number of RT products, including the DL1 CLUB, and SPEEDBOX.

<http://www.race-technology.com/wiki/index.php/Software/LiteMonitor>

10.4 The Configuration Tool

The configuration software is required to read or write the configuration on your DL1 CLUB, or to reflash it through the USB port.

<http://www.race-technology.com/wiki/index.php/Configuration/DL1MK3Configuration>

10.5 Re-Flashing Your Unit

At Race Technology, we are constantly improving our products. This means that, from time to time, you may wish to re-flash your unit with the latest firmware.

<http://www.race-technology.com/wiki/index.php/ReflashingDataLoggerDevices/ReflashingTheDL1MK3>